

Elevator and
Drag Chains

Cement Industry Chains
and Accessories



REXNORD

The Leader in Elevator Chain Design

Simply stated, an elevator chain must provide predictable wear life for the longest time possible. This factor is critical in elevator chain design to allow for planned maintenance and elimination of costly downtime. Don't risk your production with an elevator chain not designed specifically for demanding cement mill elevator service. Rexnord elevator chains are designed and manufactured by Rexnord Industries, Inc., a leader in the manufacture of heavy duty bucket elevators for cement mill service. Coupled with over 100 years of chain manufacturing experience, you can be assured that we know how to maximize elevator chain performance.



The Greatest Fatigue Strength

Bucket elevators are "fatigue machines" that generate millions of load cycles. For example, a chain elevator with 70 ft. (21.3 m) centers operating at 300 FPM (1.5 m/s) could see over 1,000,000 load cycles in just one year of service! Precisely for this reason, all Rexnord elevator chains are designed with a primary objective of providing the maximum fatigue strength that is possible.

Only Rexnord has the combination of design engineering, manufacturing technology and product testing to keep advancing the art of high fatigue strength chain production. We have tested competitive chains and, size for size, none match the fatigue strength of Rexnord elevator chains.

The Longest Wear Life

Rexnord leads the industry with its induction hardening and deep case carburizing capabilities. As a result, Rexnord elevator chain pins and bushings have the hardest and deepest case depths providing maximum wear life. In addition, Rexnord chains provided consistent wear over the life of the chain. This allows the user to predict the wear life of the chains, allowing for chain replacement as part of their preventive maintenance programs. This eliminates costly, unexpected maintenance and down time.



The Rexnord Chain Story

A lot goes into a Rexnord chain that is not visible on the surface. The precision of a pin diameter or the case depth of a heat treated pin can only be realized after an in-depth analysis. Rexnord regularly tests our chains as well as competitive chains and it is clear that all chains are not created equally. Rexnord heavy duty cement mill elevator chains are made to provide the utmost in performance and dependability.

Maximizing Fatigue Strength Through Fit and Finish

Rexnord's 100 plus years of documented testing and application experience drives the development of elevator chain designs used to meet the cement industry's need for improved fatigue strength.

But design is only the beginning. Making these chains requires a major advancement in manufacturing technology to achieve:

- Controlled and repeatable interference fits
- Superb surface finishes
- The use of finite element analysis helps us develop and maintain our position as industry leader

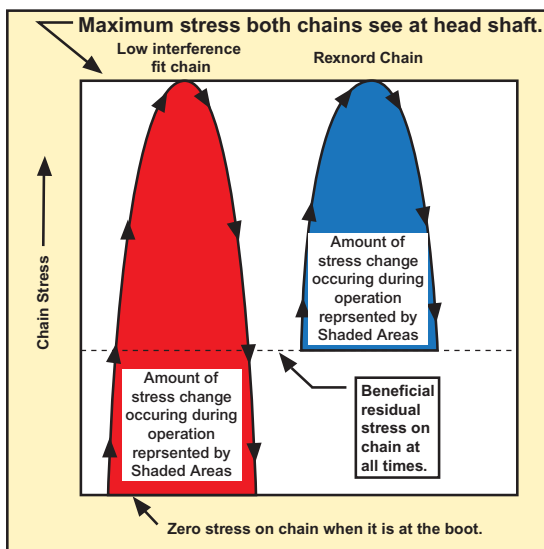

Controlled Interference Fit Through Precision Components

One of the main reasons for the durability of a Rexnord elevator chain is the optimum interference fit we achieve after assembly. The interference fit of pins and bushings creates a beneficial residual stress around the sidebar holes to significantly improve fatigue life.

To illustrate the importance of interference fit the following graph shows the range of stress that two chains might experience in an elevator as they travel from the loaded to unloaded conditions in a bucket elevator. The red line shows a low interference fit chain and the blue line shows a Rexnord chain with a controlled interference fit. The low interference fit chain starts from a zero loading position, reaches a maximum load at the headshaft, and drops back to zero at the tailshaft - a large change in stress. The Rexnord chain has a narrower change in stress as it starts from a

higher pre-stressed level, due to the controlled interference fit, rather than the lower stress level starting point of the low interference fit chain. Over many cycles, the change in stress will lead to fatigue failures. The larger the change in stress, the greater the chance that the steel may break down and cause a chain failure without warning!

Controlled interference fit comes from manufacturing components with very precise tolerances. If part diameters are not kept within a very close range, some links will have too much interference fit and others will have too little. Rexnord has spent years testing interference fit to find the optimum level for elevator chains. All Rexnord elevator chains are applied based upon fatigue curves generated from this testing.



To control the amount of interference, Rexnord uses the most advanced machine tools available today. These state-of-the-art machines yield chain pins and bushings with extremely accurate and repeatable diameters. Sidebar pin and bushing holes are made using advanced piercing techniques to produce precise hole diameters.

No one but Rexnord has invested so much in time, testing, and equipment in the pursuit of excellence in chain manufacturing.

Super Smooth Hole Finishes

In addition to controlling tolerances, sidebar hole and component surface quality is a significant part of optimizing a chain's fatigue strength. Many chain failures occur from tiny imperfections in and around the pin and sidebar holes. These imperfections result in stress concentrations that, over time, become cracks that slowly propagate with each cycle in the elevator. Eventually, these cracks lead to a sudden chain failure. Rexnord has developed advanced piercing techniques that ensure a smooth hole surface finish. As an additional step, all sidebars are shot-peened to remove surface imperfections and create beneficial residual surface stresses.

Maximizing chain wear life through science and craftsmanship

Rexnord leads the chain industry in heat treatment technology. Computer controlled heat furnaces and Rexnord designed induction heat treating equipment produce chain components with the hardest and deepest cases available.



Specialized equipment is used to heat treat sprockets and traction wheels. Rexnord's specialized carburizing and induction heating equipment for these accessories is not matched in the sprocket market!

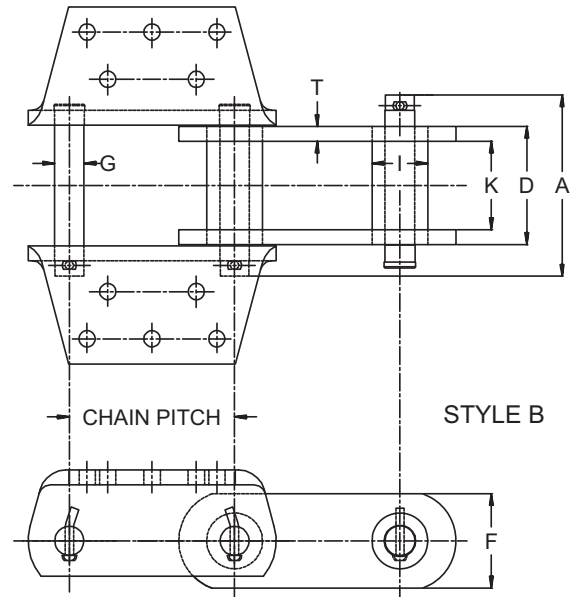
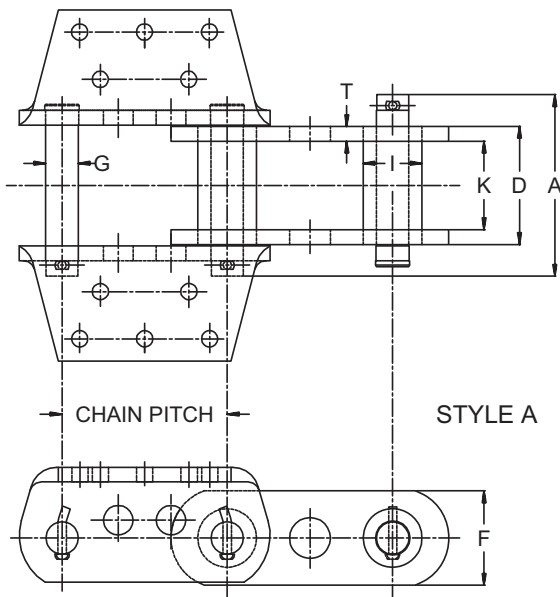

Centrifugal Elevator Chain Dimensions													
Chain Number	Pitch	Style	A	K	T	Sidebars		Pins		Bushings			SPROCKET NUMBER
						F	HEAT TREAT	G	HEAT TREAT	D	I	HEAT TREAT	
ER856	6.00 152	B	6.44 164	3.00 76.2	0.50 12.7	2.50 63.5	TH	1.00 25.4	CIH	4.00 102	1.75 44.5	CARB	856
ER956	6.00 152	A	6.44 164	3.00 76.2	0.50 12.7	3.00 76.2	TH	1.00 25.4	CIH	4.00 102	1.75 44.5	CARB	856
ER857	6.00 152	B	6.44 164	3.00 76.2	0.50 12.7	3.25 83.6	TH	1.00 25.4	CIH	4.00 102	1.75 44.5	CARB	856
ER958	6.00 152	A	6.44 164	3.00 76.2	0.56 14.2	3.25 83.6	TH	1.13 28.6	CIH	4.13 105	2.00 50.8	CARB	958
ER859	6.00 152	B	7.74 197	3.75 95.3	0.62 15.7	4.00 102	TH	1.25 31.8	CIH	5.00 127	2.38 60.5	CARB	859
ER864	7.00 178	B	7.74 197	3.75 95.3	0.62 15.7	4.00 102	TH	1.25 31.8	CIH	5.00 127	2.38 60.5	CARB	864
ER984	7.00 178	A	7.74 197	3.75 95.3	0.62 15.7	4.00 102	TH	1.38 34.9	CIH	5.00 127	2.50 63.5	CARB	984
ER1084	7.00 178	C	8.60 218	4.43 113	0.75 19	4.50 114	TH	1.62 4.1	CIH	6.00 152	2.85 72.4	CARB	1084

Consult with Rexnord engineering for elevator chain selection and application.
 TH: Thru-hardened CIH: Circumferential Induction Hardened after thru-hardening CARB: Carburized
 Dimensions shown are in inches. Red dimensions are millimeters
 Dimensions are subject to change. Certified drawings are available upon request.

800 Series and 900 Series Elevator chains

Rexnord introduced the original 800 Series of elevator chains in the 1950's. The strength and wear resistance provided by these chains allowed elevators to be built taller and run faster than ever before. Rexnord continues to increase the performance of the 800 Series through improvements in manufacturing technology.

The 900 Series of chains was created to provide even more strength than the present 800 series. Rexnord gave the 900 Series larger components to provide a minimum of 30% greater fatigue strength.

This greater strength may be used for additional capacity in new elevators, or it may be used to provide a low cost solution to an existing elevator problem. Both the 800 and 900 Series are produced to the same high quality and premium performance specifications.

The 900 Series conveniently interchanges with the 800 Series chains. Now upgrading your elevator can be as simple as replacing your chain! Contact Rexnord for application assistance.

ER856 versus ER956

Benefit: Provides 30% greater fatigue strength. Operates on same traction wheel and sprocket. Bucket hole spacing is identical.

ER857 versus ER958

Benefit: Provides 30% greater fatigue strength. Operates on same traction wheel but sprockets are different. Bucket hole spacing is identical.

ER864 versus ER984

Benefit: Provides 30% greater fatigue strength. Operates on same traction wheel but sprockets are different. Bucket hole spacing is identical.

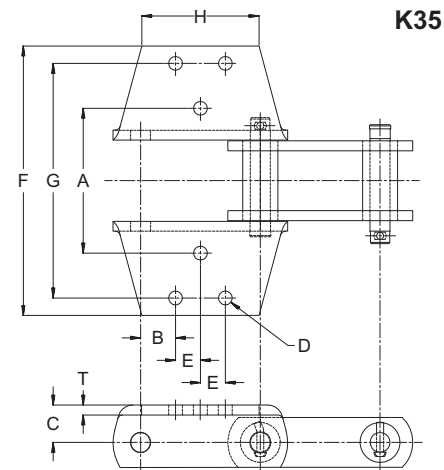

K35

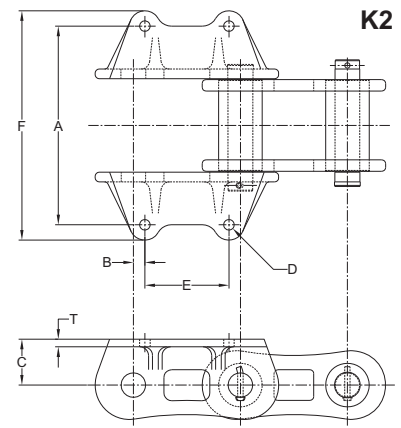

K2

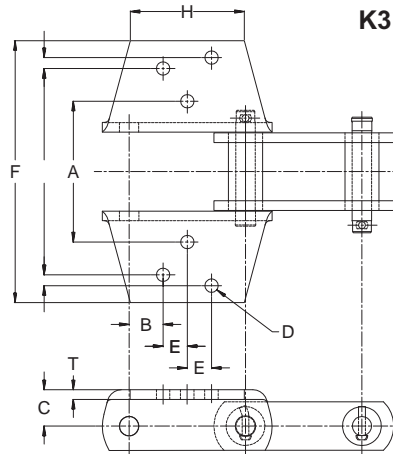

K3

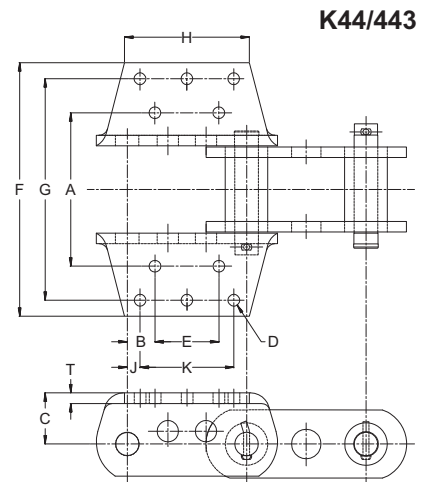

K44/443

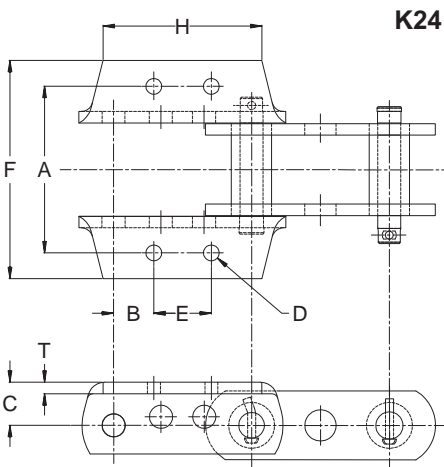

K24

Centrifugal Elevator Chain Attachments													
Chain Number	Attachment Style	A	B	C	D	E	F	G	H	J	K	T	Weight*
ER856	K24	7.25	1.75	1.88	0.69	2.50	9.38		6.91			0.50	27.5
		184	44.5	47.8	17.5	63.5	238		176			13	40.9
ER956	K24	7.25	1.75	1.88	0.69	2.50	9.38		6.91			0.50	29
		184	44.5	47.8	17.5	63.5	241		176			13	43.2
ER857	K44	7.00	1.25	2.50	0.56	3.50	14.00	12.00	5.50	1.25	3.50	0.50	38
		178	32	64	14	89	356	305	140	31.8	88.9	12.7	56.5
ER859		9.00	1.62	3.00	0.69	2.75	15.00	13.00	5.92	0.75	4.50	0.62	59
	K44	229	41.1	76.2	17.5	69.9	381	330	150	19.1	114	15.7	87.8
ER958		7.00	1.25	2.50	0.56	3.50	13.68	12.00	5.75	1.25	3.50	0.50	40
	K44	178	31.8	63.5	14.2	88.9	347	305	146	31.8	88.9	12.7	59.5
ER864		9.00	1.62	3.00	0.69	3.75	15.00	13.00	7.00	0.75	5.50	0.62	55
	K443	229	41.1	76.2	17.5	95.3	381	330	178	19.1	140	15.7	81.8
ER984		9.00	1.62	3.00	0.69	3.75	14.88	13.00	7.32	0.75	5.50	0.62	58
	K443	229	41.1	76.2	17.5	95.3	378	330	178	19.1	140	15.7	86.3
ER1084		K2	13.00	0.75	3.00	0.69	5.50	15.00					0.50
	K2	330	19.1	76.2	17.5	139.7	381					12.7	76.7
ER856		K3	6.56	1.63	1.88	0.50	1.38	13.56	10.94	4.25			0.50
	K3	167	41.4	47.8	12.7	35.1	344	278	108			13	40
ER856		K35	7.25	1.75	1.88	0.69	1.25	13.50	11.75	5.88			0.50
	K35	184	44.5	47.8	17.5	31.8	343	298	149			13	40

Consult with Rexnord engineering for elevator chain selection and application.
 TH: Thru-hardened CIH: Circumferential Induction Hardened after thru-hardening CARB: Carburized
 Dimensions shown are in inches. Red dimensions are millimeters
 Dimensions are subject to change. Certified drawings are available upon request.

Rexnord Exclusive Pre-lubricated Sealed Joint Elevator Chains

Rexnord's patented seal keeps grease in and abrasive materials out of the chains joint to significantly improve chain joint life. This unique design couples a resilient seal (blue) with a hardened steel retaining ring (red) to completely seal off the chain joint from fine abrasives. Equally as important, the seal retains factory installed grease (green) in the chain joint to dramatically reduce the wear of the chain. Nothing else in the industry comes close.

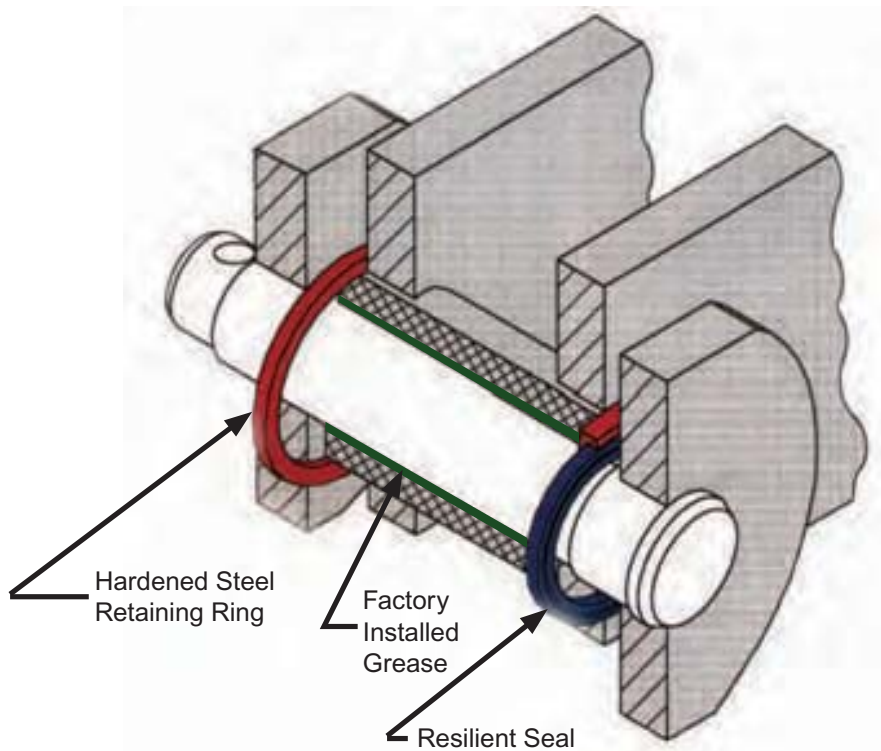

When to Consider the Sealed Joint Option

Sealed joint chains are more expensive than standard chains. Therefore, some forethought must be given to the proposed application so that the greater expense justifies itself. Severe pin wear in finished cement elevators or pin corrosion due to corrosive environments can be reduced with the sealed joint. The standard seal is limited to 250°F (121°C). A higher temperature seal material is available. Rexnord engineers are available to discuss any applications you may be considering.

Available Chains

Many elevator chains are available with this option. Sealed joint chains have a "SJM" prefix that replaces the "ER" prefix. As an example, to order an ER984 as a sealed joint chain one would describe it as SJM984. Straight sidebar drive chains and many other straight sidebar conveyor chains are also available with this option. Let us work with you to tailor a chain for any problem applications you may have.

Rexnord® Heavy Duty Drag Chain made in the USA

Reduce maintenance and downtime with Rexnord heavy duty welded drag chain while increasing your conveying efficiency!

This premium performance drag chain features:

- Hardface welding on both of the chain's sliding surfaces as standard. A typical weld hardness of 58 Rc and a heavy weld bead give this chain excellent wear resistance in cold clinker applications.
- Interference fit between the pin and chain sidebar dramatically improves chain strength and joint wear life over that of cast drag chain. No loose pins to move around the chain joint.
- An Induction Hardened pin gives the best of two worlds – a 60 Rc typical case and tough, impact resistant material in the balance of the pin. The result: wear resistance coupled with impact resistance.
- Square edges on the wing and sidebar or welded drag chain conveys more efficiently than rounded cast chain edges and moves a deeper bed of material with each revolution of the chain.
- Heat treated and fabricated steel components eliminate the failures that cast chains experience from casting porosity and inclusions.

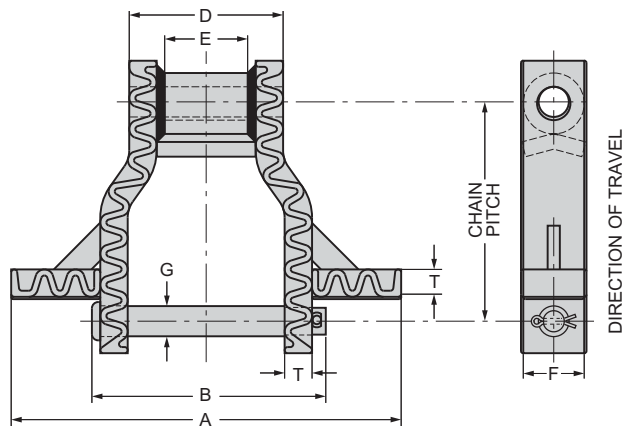

Heavy Duty Welded Steel Drag Chain												
Chain Number	Pitch	A	Sidebars			Pins			D	E	Rated Working Load	Sprocket Number
			T	F	Heat Treat	B	G	Heat Treat				
WHX5157	6.05	8 - 14"	0.63	2.50	TH	6.94	1.13	SIH	4.63	2.75	18,200	5157
	154	203 - 356	16	63.5		176	28.7		118	69.9	81,000	
WHX6067	9.00	10 - 26"	0.75	2.50	TH	8.19	1.25	CIH	5.5	6.63	24,300	6121
	229	254 - 660	19.1	63.5		208	31.8		140	92.2	108,000	
WHX5121*	9.00	10 - 30"	1.13	2.50	TH	9.75	1.25	CIH	6.31	6.63	27,600	6121
	229	254 - 762	28.7	63.5		248	31.8		160	92.2	123,000	
WHX6121	9.00	10 - 30"	1.13	2.50	TH	9.75	1.25	CIH	6.31	6.63	27,600	6121
	229	254 - 762	28.7	63.5		248	31.8		160	92.2	123,000	

*WHX 5121 is dimensionally the same as WHX 6121 except it runs closed end forward.

TH: Thru-hardened CIH: Circumferential Induction Hardened after thru-hardening CARB: Carburized

Dimensions and working loads are shown in inches and pounds. Red dimensions and working loads are in millimeters and newtons.

Dimensions are subject to change.

Certified drawings are available upon request.

Continuous Discharge Dual Strand Elevator Chains

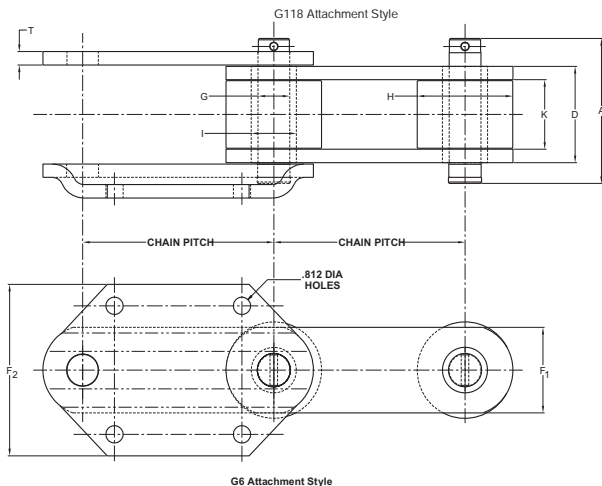
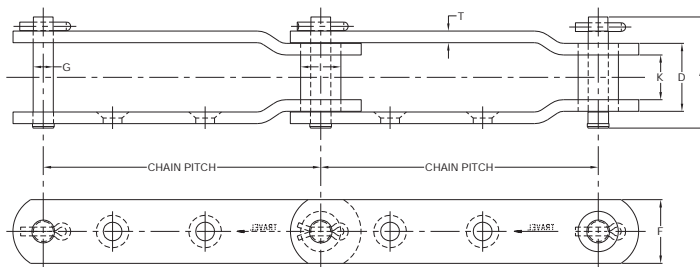
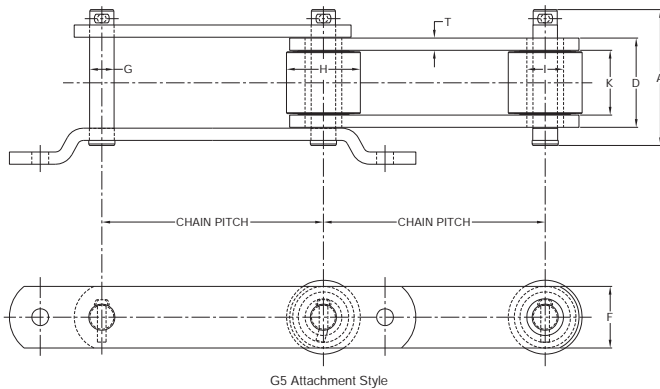

4000 Series Chain

The 4000 series chain is a 12" pitch chain that utilizes only one pitch per bucket. Rexnord's all-steel fabricated chains are precision built with high quality steel that incorporates advanced heat treating methods to prolong wear life. The chain is then matched in pairs for true dual performance with end hung buckets. It is furnished with G118 attachments.

4100 Series Chain

The 4100 Series is a 9" pitch chain that utilizes 2 pitches per bucket. It has all of the features of the 12" pitch chain, but the shorter pitch permits higher speeds which means greater capacities. The 4100 series chain is furnished with either a G5 or a G6 attachment.

Continuous Discharge Dual Strand Elevator Chain Dimensions

Chain Number	Pitch	A	K	T	Sidebars		Heat Treat	Pins		Rollers		Bushings			Rated Working Load	Sprocket Number
					F	F2		G	Heat Treat	H	Heat Treat	D	I	Heat Treat		
R4251-G118	12.00	4.63	1.94	0.50	2.00		TH	0.88	CARB	1.75	CARB	2.94	1.25	CARB	9,000	4251
		305	118	49.3	12.7	50.8		22.4		44.5		74.7	31.8		40,000	
R4004-G5	9.00	5.69	2.63	0.50	2.50		TH	1.00	CIH	3.00	CARB	3.63	1.50	CARB	12,700	4004
		229	145	66.8	12.7	63.5		25.4		78.2		92.2	38.1		56,500	
R4065-G5	9.00	6.16	3.06	0.63	3.50		TH	1.25	CIH	4.25	CARB	4.31	2.00	CARB	18,900	4065
		229	156	77.7	16	88.9		31.8		108		109	50.8		84,000	
R4037-G6	9.00	6.79	3.25	0.62	4.00	8.00	TH	1.50	CIH	4.50	CARB	3.25	2.12	CARB	29,500	4037
		229	172.5	82.55	17.75	101.6		38.1		114.3		82.55	53.85		131,255	

R4251-G117 has .56 inch diameter countersunk bolt holes

R4251-G118 has .81 inch diameter countersunk bolt holes

TH: Thru-Hardened CIH : Circumferentially Hardened after thru-hardening CARB: Carburized

Dimensions and working loads are shown in inches and pounds. Red dimensions and working loads are in millimeters and newtons.

Dimensions are subject to change.

Certified drawings available upon request

Rexnord Components.....Matched for high performance



Casings: Head Sections

Rexnord Super Capacity elevators are designed with a split, removable upper head section manufactured of #12 gauge steel with dust seals to seal shaft openings. This design also incorporates channels that ring the lower head section to help form headshaft bearing support helps to insure proper bearing life and maximum machinery life. Our lower head section casings are all jig welded and are fabricated from 1/4" (6 mm) steel with heavy structural stanchions under the bearing support ring. The discharge chute is fabricated of #7 gauge steel with a 3/8" (9.5 mm) bottom plate for wear resistance. The Head section also includes easy access doors for discharge lip inspection and maintenance.

Clawmaster Chain assembly tool

Keep the advantage of the high interference pin fit by using the "ClawMaster" assembly and disassembly tool for all Rexnord elevator chains. Use of this tool eliminates pin grinding or the heating of side bars which destroys the fatigue strength of the chain and can result in premature chain failure. This rugged device incorporates an improved arm design that helps reduce breakage and increases power by 2 1/2 times by using a hydraulic ram and hand pump to deliver the extremely high forces necessary to drive chain pins in the field or in the shop. The holes in the arms aid in handling the tool by providing key anchor points for crane lifting or manual handling. This tool can be used for efficiency in both chain assembly and disassembly. Request bulletin No. 5016 for more details.



Elevator Buckets

Over 80 years of elevator design gives us practical application experience that we have used to help design our buckets. Rexnord Super Capacity Style AC and ACS buckets are designed to elevate and properly discharge a wide range of bulk material. Buckets are fabricated from 7 gauge steel plates and the use of deep continuous welds to assure high strengths for severe service applications. Other thicknesses are available upon request. To meet your specific needs, buckets are available with AR wear lips and non stick liners if needed. HL buckets are continuously mounted and end hung on two strands of chain with bearing plates which redistributes the load to avoid cracking at the bolt holes.

Boot Sections:

The Rexnord Super Capacity elevator boot section is fabricated from ¼" (6mm) steel plate with a detail on the heavy corner angles that are jig welded to assure that the elevator is given a square and dimensionally true beginning assembly point. Removable front and rear clean out panels, along with large double-hinged access doors make inspections and clean-outs simple. The Rexnord gravity take up with a built in counter weight are standard equipment as well as the take up hoist beam for maintenance use.



Segmental Sprockets

Segmental sprockets are easily installed, simplifying replacement without disassembling body, chain or shaft assemblies. Heavy-duty solid steel rim sprockets are factory fastened to the body using Huck fasteners, offering positive rim/ fastener retention without concern of loosening during operation. Sprocket rim segments are made to wear-resistant specifications, deep carburized and induction hardened to 60 RC. Sprocket segments are reversible for double life. Head shaft assemblies are furnished with solid bodies utilizing keyless locking ring assemblies as standard in high performance elevators. Keyless locking rings insure positive wheel retention to shaft without stress points associated with keyed shafts.

Rexnord Planetgear Shaft Mount Planetary (SMP)

The Rexnord Shaft Mounted Planetgear (SMP) Reducer Series is a perfect alternative to traditional helical shaft mounted reducers.

The new SMP Series incorporates all the standard Planetgear features you've come to expect for your heavy-duty applications. The self-aligning gear train in contact per reduction equally share the load, and is directly mounted on the driven shaft, eliminating the need for a low speed coupling, chain drive or reducer mounting base.



Our new Hercules reducer expands our offering to applications requiring output torque up to 2.9 million lb-in.



Segmental Traction Wheels

All the heat treat and hardening expertise that goes into our chain is applied to Rexnord's traction wheels and sprockets. A matched set of traction wheels assures a smooth system operation. Plus, Rexnord's unique ability to achieve deep and hard case depths provides the longest wearing components available. Don't settle for a substandard drive component when you purchase a premium elevator chain.

Ni-Hard Bearings

Cast Ni-Hard take up bearings and Ni-Hard sleeves require no lubrication and no periodic maintenance, thus ensuring a long service life and less maintenance headaches.



World Class Customer Service

For more than 100 years, the dedicated people of Rexnord have delivered excellence in quality and service to our customers around the globe. Rexnord is a trusted name when it comes to providing skillfully engineered products that improve productivity and efficiency for industrial applications worldwide. We are committed to exceeding customer expectations in every area of our business: product design, application engineering, operations, and customer service.

Because of our customer focus, we are able to thoroughly understand the needs of your business and have the resources available to work closely with you to reduce maintenance costs, eliminate redundant inventories and prevent equipment down time.

Rexnord represents the most comprehensive portfolio of power transmission and conveying components in the world with the brands you know and trust.

WORLDWIDE CUSTOMER SERVICE

AUSTRALIA

Rexnord Australia Pty. Ltd.
Picton, New South Wales
Phone: 61-2-4677-3811
Fax: 61-2-4677-3812

Falk-Rexnord Australia Pty Ltd
Broadmeadow New South Wales
Phone: 61-2-4962-8000
Fax: 61-2-4962-8001

BRAZIL

Rexnord Correntes Ltda.
Sao Leopoldo - RS
Phone: 55-51-579-8022
Fax: 55-51-579-8029

CANADA

Rexnord Canada Ltd.
Scarborough, Ontario
Phone: 1-416-297-6868
Fax: 1-416-297-6873

CHINA

Rexnord China
Shanghai, China
Phone: 86-21-62701942
Fax: 86-21-62701943

EUROPE

Rexnord NV/SA
Mechelen, Belgium
Phone: 32-15-443881
Fax: 32-15-443860

LATIN AMERICA

Rexnord International
Milwaukee, Wisconsin
Phone: 1-414-643-2366
Fax: 1-414-643-3222
E-mail: international1@rexnord.com

MEXICO

Rexnord S. A. de C. V.
Mexico DF, Mexico
Phone: 52-55-9140-3500
Fax: 52-55-9140-3550

SINGAPORE

Rexnord International, Inc.
Singapore City, Singapore
Phone: 65-6338-5622
Fax: 65-6338-5422

UNITED STATES

Customer Service
Phone: 866-Rexnord
(866-739-6673)
E-mail: [rexnordcs\(state\)@rexnord.com](mailto:rexnordcs(state)@rexnord.com)
Example: rexnordcsohio@rexnord.com

ALL COUNTRIES NOT LISTED ABOVE

Rexnord International
Milwaukee, Wisconsin
Phone: 1-414-643-2366
Fax: 1-414-643-3222
E-mail: international2@rexnord.com

